

SwineTech: Development of Cost-Efficient Automated Feeding and Watering System for Small-Scale Piggeries with Real-Time Monitoring of Stocks

Eric C. Dela Cruz Jr., Karla Mae D. Marzan, Mary Rose C. Simangan, Kimberly Ann C. Tugade, and Paulina A. Marzan, CpE

ABSTRACT

This study presented the design and development of SwineTech, an automated feeding and watering system tailored for small-scale piggery operations in rural settings, particularly in Salinas, Bambang, Nueva Vizcaya. Recognizing the inefficiencies and labor demands of traditional pig farming methods, the system integrates hardware and software solutions to automate feeding schedules and monitor feed and water stock levels in real-time. The system alerts users via SMS when critical thresholds are reached, enhancing resource management and reducing human error. The system operates on scheduled routines and alerts the user via SMS when feed or water reaches warning or critical levels, ensuring timely replenishment. It also minimizes manual labor and improves feed consistency. Through trial runs, the prototype achieved a 95% dispensing accuracy and reduced feed wastage by up to 75%. A side-by-side comparison with manual methods showed significant improvements in time efficiency, resource use, and daily operational costs. Financial analysis confirms the viability of SwineTech, with an estimated return on investment within four to five months and a projected lifespan of five to seven years. The system's low production cost, modular design, and adaptability to different pig growth stages make it an accessible and sustainable solution for rural farmers. By leveraging simple yet effective automation, this project empowers small-scale pig raisers to modernize their operations, increase productivity, and improve overall animal welfare.

Keywords: Swine, Dispensing, Automated, small-scale piggeries, real-time

INTRODUCTION

Small-scale piggery operations are vital to the Philippine agricultural sector, especially in rural provinces like Nueva Vizcaya, where pig raising serves as a major source of livelihood. With pork as one of the most consumed meat products, many farmers rely on backyard piggery systems, which account for about 84.86% of the province's total hog population. However, these farms still depend on manual feeding and watering methods, which are labor-intensive, inefficient, and prone to error. Such practices often lead to overfeeding, underfeeding, inconsistent water supply, and poor monitoring of feed stocks, ultimately reducing farm productivity and profitability.

While large-scale farms have begun adopting automated systems to improve efficiency, small-scale pig raisers face barriers such as high costs, technical complexity, and lack of expertise. To address this, the proposed project, SwineTech, aims to develop an affordable and user-friendly automated feeding and watering system for small-scale piggeries. This system will automate feed and water delivery, monitor stock levels in real time, and promote efficient resource utilization—helping farmers save labor, reduce waste, and improve animal health.

Related studies highlight the benefits of automation in pig farming. Buenaflor et al. (2024) designed an automated feeding system with scheduling and monitoring features, reducing labor costs and piglet mortality. Likewise, Lee et al. (2021) developed a sensor-based

system using RFID and machine learning, which improved feed efficiency and reduced waste. These findings emphasize that automation can significantly enhance farm operations, making it an essential step toward sustainable and productive piggery management in the Philippines.

Conceptual Framework

The flow of the system starts with the power supply, which activates the system to work. The inputs are then registered into the system, including the number of pigs in one cell, their age, and the cellphone number of the user. The feed and water storage are built with sensors to monitor stock levels. It comes with a dispenser and an open and close mechanism in which the user decides either to dispense or to withhold the process. When the process is done, the system will inform the user through feedback using the GSM on whether the process is successful or unsuccessful; also, the current amount of feed and water stocks is sent to the user for better monitoring.

The system begins with collecting essential piggery data, such as the number of pigs and the schedules for feeding and watering. Feed and water stock are also monitored, ensuring the availability of resources. Schedules and settings are also established to provide a predefined plan when the system will dispense feed and water. The system uses automated feeding and watering to provide the feed and water to the pigs according to the pre-set schedules and data.

Efficient feeding and watering are achieved, optimizing the use of resources while ensuring the smooth flow of the piggery when it comes to its feeding and watering processes. Stock management improves as the system ensures resources are utilized effectively without wastage. Lastly, the evaluation of effectiveness provides insights into how well the system is performing, allowing for continuous improvement in the piggery management process. Overall, this framework suggests a streamlined and technology-driven approach to enhancing the efficiency and productivity of pig farming.

METHODOLOGY

Research Design

The study utilized AGILE Methodology focusing on system development of the cost-effective automation of feeding and watering systems for small pig farms. Through this approach, the research adapted to the focus and methods based on real-time findings.

The AGILE methodology used methods that can be adjusted based on real-time findings and emerging insights. This approach enabled the research team to respond effectively to evolving requirements, challenges, and opportunities throughout the research process. The study aimed to develop a cost-effective automated feeding and watering system for small-scale piggeries, integrating monitoring feed and water stocks.

Research Locale

The research was conducted in Bambang, Nueva Vizcaya, which houses several pig raisers all over the municipality. The study aimed to automate the feeding and watering systems of the piggeries and optimize the monitoring of the level of feed and water stocks in this specific location to help the raisers with their daily chore of feeding and watering their piggeries.

Research Participants

The participants of the study were the pig raisers in Salinas, Bambang, Nueva Vizcaya. They played a crucial role in providing insights into their current operations, such as how they feed and water their piggeries and monitor their stocks. They also provided information on how they handled challenges posed by their traditional way of feeding and watering.

The sample for this research was selected using purposive sampling, ensuring that the participants had relevant knowledge and experience in pig raising, particularly in feeding and watering systems and monitoring the current stock of goods of the pigs. This approach allowed for a focused and in-depth exploration of specific issues related to the feeding and watering of pig raisers in Bambang, Nueva Vizcaya.

Research Instrument

The project used verbal consultation to obtain the needed data. The feeding and watering phases of the piggery were also evaluated using this tool. Among the data obtained during the consultation were the feeding and watering practices, resource management, and piggery location. Online research was also done to gain an in-depth understanding of the data and problems presented. This combination of tools ensured a comprehensive understanding of the current practices, challenges, and feasibility of implementing SwineTech in Bambang, Nueva Vizcaya's small-scale piggery operations.

System Architecture

The user can automatically control the system with the help of GSM Antenna as a bridge of connection between the system and the user. SwineTech will have its predetermined level set by the user.

The monitoring of stocks is done through sensors, at which a pre-warning and critical (empty) level is determined. The weight sensor will gather the data needed, such as the weight of feeds and the water level in the reservoir, to determine if the stocks are at the pre-warning level and when it is at a critical level, with enough only to feed and water the pigs once. The system will send an alert once it reaches the pre-warning level and another one again to notify the user about the refill of stocks if the sensor reaches the critical level.

The microcontroller that is connected to both sensors from the system will then process the data. The GSM module is programmed to handle communication with the Antenna, which will transmit data to the mobile device used by the user. The user will then be alerted through an SMS, controlled by GSM, and with inputs from the system. The SwineTech will only be used within the piggery and only with the user.

The researchers, who are also the administrators of the system, will enter the pig raiser's mobile number, after which they will receive a message from the system to confirm the connection between the user and the system. Users not registered to access the system cannot bypass nor alter the system's process.

Data Gathering Procedure

The data-gathering process involved a simple consultation with small-scale piggery raisers to obtain first-hand experience and knowledge about taking care of pigs. Through careful analysis of these, adjustments to the developed system for feeding and watering can be applied and monitored.

The selection of small-scale piggery owners as consultation participants was based on their expertise and experience in taking care of pigs. By targeting people who had practical knowledge of feeding and watering, the researchers gathered valuable insights and real-world

perspectives on the effectiveness of a system added to their piggery. This first-hand information was crucial in identifying the specific challenges and potential areas for improvement in the developed system for small-scale piggeries. The data gathered from the interviews were carefully analyzed to identify common themes, patterns, and emerging concepts.

The analysis involved transcribing the interviews, coding the data, and organizing the information into meaningful categories. This process identified the key factors that contribute to feeding and watering and provided valuable insights for adjusting and refining the developed system for small-scale piggeries.

Treatment of the Data

For the SwineTech project, treatment of data involved the structured collection of operational and experimental conditions to assess system performance, validate functionalities, and ensure reliable outcomes. This data included several categories critical to the project's success. Firstly, feed distribution data involved recording the amount of feed dispensed per session, the frequency and timing of feeding, and the type of feed used, such as starter, grower, or finisher feeds. Similarly, water dispensing data included the volume of water dispensed per session, the frequency and timing of watering, and parameters like water source and quality. The system's real-time monitoring parameters included feedstock levels, water stock levels, sensor readings such as weight, and triggered alerts for low feed or water levels. The system tracked pigs in terms of feeding activity and water consumption patterns. The project's performance was evaluated using system performance, such as the power supply, timer, dispenser, feed/water storage, and close and open mechanisms. To measure the system's impact, the study compared a control group, fed and watered manually, with a treatment group using the SwineTech system.

RESULTS AND DISCUSSION

This chap presents the findings derived from the research, offering a detailed analysis and interpretation of these findings. The presentation of the results is structured to directly address the research questions and hypotheses established in the first chapters. Subsequently, the discussion section provides a thorough interpretation of the results, establishes connections with relevant existing literature, and explains the broader implications of the research.

Design and Development

The development of Project SwineTech mobilizes the usage of Arduino UNO, motor driver, sensors, and GSM SIM800L V2 hardware.
Hardware Specification for Project SwineTech

1. Arduino UNO

- Microcontroller: ATmega328P
- Operating Voltage: 5V
- Digital I/O Pins: 14 (6 PWM outputs)
- Analog Input Pins: 6
- Flash Memory: 32 KB (0.5 KB used by bootloader)
- SRAM: 2 KB
- EEPROM: 1 KB

2. Load Cell

- Type: Parallel beam load cell
- Capacity: 100 kg
- Output: Millivolt signal
- Connection: HX711 amplifier for signal conditioning

3. HX711 Amplifier

- Type: Precision 24-bit ADC
- Power Supply: 2.6V to 5.5V
- Interface: Serial communication with Arduino

4. Stepper Motor

- Type: NEMA 17
- Holding Torque: 45 Ncm
- Voltage Rating: 12V
- Control Method: DRV8825 driver

5. DRV8825 Stepper Motor Driver

- Input Voltage: 8.2V to 45V
- Current Control: Adjustable via potentiometer
- Microstepping: Up to 1/32 micro stepping

6. GSM SIM800L V2 Module

- Power Supply: 3.4V to 4.4V
- Communication: Serial
- Features: SMS, GPRS, and voice capability
- Antenna: External antenna for better signal reception

7. Ultrasonic Sensor (HC-SR04)

- Operating Voltage: 5V
- Measurement Range: 2 cm to 400 cm
- Accuracy: Up to 3 mm
- Interface: Trigger and Echo pins for distance measurement

8. RTC Module (DS1307 or DS3231)

- Power Supply: 5V
- Interface: I2C
- Accuracy: DS3231 has built-in temperature compensation

9. Power Supply

- Main Supply: 12V for motor driver and other components
- Breadboard Supply: 5V for Arduino and sensors

The schematic diagram for the project, presented in Figure 5, illustrates the configuration in which the GSM SIM800L V2, stepper motor, and sensors are connected, detailing the specific connections, including power supply routing, signal pathways for data transmission between the GSM SIM800L V2 and the microcontroller, and control lines for the stepper motor and sensor interfaces.

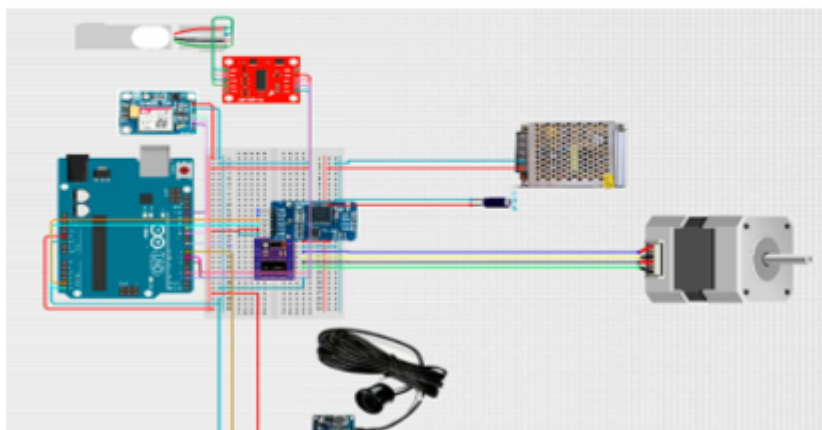
Figure 1*Schematic Diagram of SwineTech***Hardware Development****Connecting the Arduino UNO with the different modules**

In setting up the connections for the Arduino UNO to interact effectively with its modules, the following steps were done:

1. Load Cell (Refer to Figure 6)
 - 1.1. Connect load cell wires to an amplifier
 - 1.2. Connect the amplifier to Arduino UNO
 - 1.2.1. VCC to breadboard's power rail
 - 1.2.2. GND to breadboard's ground rail
 - 1.2.3. LOADCELL_DOUT to digital pin 3
 - 1.2.4. LOADCELL_SCK to digital pin 2
2. Stepper Motor and Driver (Refer to Figure 7)
 - 2.1. Connect the stepper motor wires to the stepper motor driver DRV8825
 - 2.2. Connect the stepper motor driver to the Arduino
 - 2.2.1. STEPPER_STEP to digital pin 6
 - 2.2.2. STEPPER_STEP to digital pin 5
 - 2.3. Power
 - 2.3.1. Connect the separate 12V power supply to the stepper motor driver's power input.
 - 2.3.2. Connect the 12V power supply's ground to the breadboard ground rail
3. GSM SIM800L (Refer to Figure 8)
 - 3.1. Connect SIM800L VCC to the breadboard's power rail
 - 3.2. GND to Arduino GND
 - 3.3. Connect SIM800L to Arduino
 - 3.3.1. GSM_RX to digital pin 10
 - 3.3.2. GSM_TX to digital pin 11
 - 3.4. Attach antenna to SIM800L
4. Ultrasonic Sensor (Refer to Figure 9)
 - 4.1. Connect the sensor to the Arduino
 - 4.1.1. VCC to breadboard's power rail
 - 4.1.2. GND to breadboard's ground rail
 - 4.1.3. Trig to digital output 7
 - 4.1.4. Echo to digital input 8
5. RTC Module (Refer to Figure 10)
 - 5.1. Connect the RTC Module to Arduino using I2C
 - 5.1.1. VCC to breadboard's power rail
 - 5.1.2. GND to breadboard's ground rail

- 5.1.3. SDA to Arduino SDA (A4)
- 5.1.4. SCL to Arduino SCL (A5)
- 5.2. Interaction between the RTC and the modules
 - 5.2.1. RTC provides real-time data (time and date) to the Arduino
 - 5.2.1.1. Control stepper motor movements based on the schedule

Figure 2

Load Cell Connection

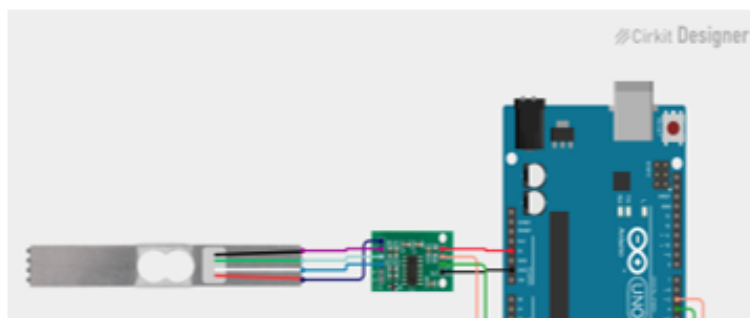

Figure 3

Stepper Motor and Driver Connection

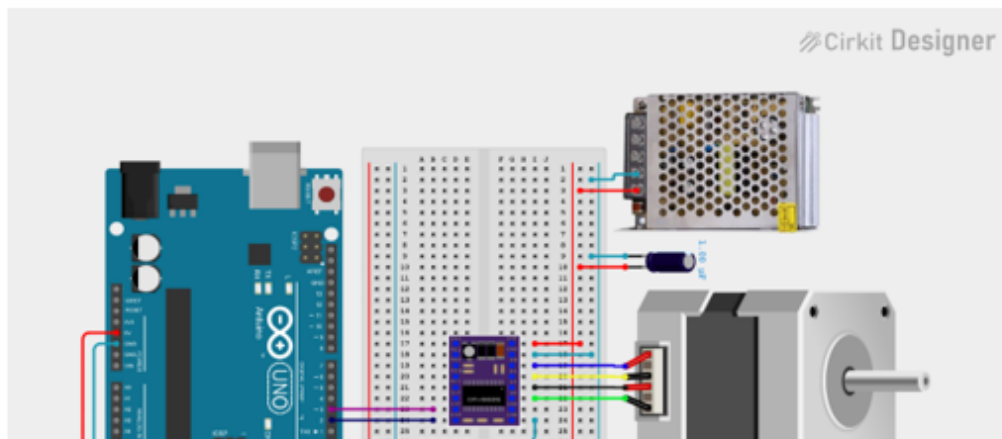
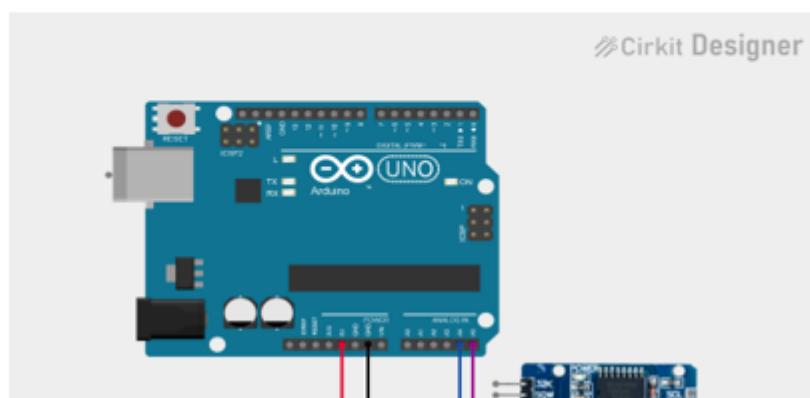

Figure 4

GSM SIM800L V2 Connection

Figure 5*RTC Module Connection*

Programming the Arduino UNO and the modules through Arduino IDE

To effectively connect and establish interaction between the Arduino and the modules, the following steps are as follows:

1. Install Arduino IDE v1.8.3 or Arduino 2.3.4
2. Open the software application
3. Create the functional program for each module
 - 3.1. Load Cell
 - 3.2. Stepper Motor
 - 3.3. GSM SIM800L
 - 3.4. Ultrasonic Sensor
 - 3.5. RTC Module
4. Based on the connection of pins of the modules incorporated in the Arduino UNO, encode the program and its functionalities.
5. Compile the program for each module and ensure that every line works well and effectively.

6. Plug the Arduino UNO into the laptop. Ensure that the Arduino board is connected to the correct port through the 'Port' and that the type of board used is chosen correctly under the 'Board Manager,' both set in the 'Tools' menu.
7. 'Compile' the program and check if there are errors that need to be revised.
8. 'Upload' the program into the Arduino UNO.
9. Check if the modules are working accordingly and respond based on the programmed code.

Prototyping Project SwineTech

The making of the Project SwineTech prototype

1. Constructing the machine prototype
 - 1.1. Design the framework
 - 1.2. Assemble the structure
 - 1.3. Install the water tank (Refer to Figure 11)
 - 1.4. Attach the feed container (Refer to Figure 12)
2. Incorporating the modules into the prototype
 - 2.1. Integrating the stepper motor and load cell in the feed container (Refer to Figure 6)
 - 2.2. Setting up the ultrasonic sensor in the water tank (Refer to [Figure 9](#))
3. Connect all the modules and Arduino UNO through the breadboard
4. Ensure that all connections are working by running initial tests and refining the program based on the output of the prototype.

Figure 7
Water Tank of Project SwineTech



Figure 8
Feed Container of Project SwineTech



Programming the Modules

1. Load cell and amplifier (Refer to Figure 6)
 - 1.1. Install and include the HX711 library
 - 1.2. Define the Arduino pins connected
 - 1.3. In setup (), initialize the HX711 object
 - 1.4. Calibrate the load cell and input the necessary details to get accurate readings.
 - 1.5. In loop (), read the weight from the HX711 using a function from the library.
 - 1.6. Add the additional clauses for the program's functionalities
 - 1.7. If the read output is below the predefined level of the feed container, a warning will be sent through the GSM SIM800L
2. Stepper motor and driver (Refer to figure 7)
 - 2.1. Include AccelStepper.h library
 - 2.2. Define the Arduino pins connected to the stepper motor driver's control pins.
 - 2.3. Initialize the stepper motor
 - 2.4. Add the additional clauses for the program's functionalities
 - 2.4.1. Scheduled time to when the motor will activate
 - 2.5. Use functions to control the motor under the loop()
3. GSM SIM800L (Refer to figure 8)
 - 3.1. Include the software serial library
 - 3.2. Define the Arduino pins for RX and TX
 - 3.3. Initialize serial communication with the SIM800L
 - 3.4. Add the additional clauses for the program's functionalities
 - 3.4.1. Input the cellphone number of the user
 - 3.5. In loop(), set commands to send information based on the output from the water tank and feed container
4. Ultrasonic Sensor (Refer to figure 9)
 - 4.1. Define the Arduino pins connected to the sensor's pins
 - 4.2. In loop(),
 - 4.3. In pulseIn(),
 - 4.4. Add the additional clauses for the program's functionalities
 - 4.4.1. Input the predefined water levels for the warning and critical levels
 - 4.5. Calculate the distance of the surface level of the water. If it falls below the predetermined normal level, a message will be sent to the user through the GSM SIM800L.
5. RTC module (Refer to Figure 10)
 - 5.1. Install and include a library for the specific RTC module (RTClib and wire.h library)
 - 5.2. Set and initialize the time for the module to work on schedule in the setup()
 - 5.3. In loop(), use the library to get the current date and time
6. Compile the programs of the module in one program. Ensure that every line of the program is working together with the targeted function of the module (Refer to Figure 18)

According to the data released by UNAHCO Philippines, a leading integrated agriculture and animal healthcare company in Asia, the data shown in Table 1 shows the ideal amount of food that pigs should have. Depending on the stage of growth for pigs, the feed, day of feeding, and amount per day varies. Further, in an oral consultation conducted in Salinas, approximately the same amount, if not greater, is stated by the local pig raisers as their habitual and how they really grow their own. Acknowledging and integrating this data into the predefined data of the

system ensures that the amount of feed dispensed and its scheduled time of feeding conform to the needs of the pigs for growth and development.

Feed Dispensing

To enable approximate dispensation of feed per pig pr, pig pen test runs were made using the integration of the load cell stepper motor with its driver and auger. After some testing, the result is that for the feed to dispense at the approximate amount the pigs need per meal, it should have about 14 revolutions to dispense about 1.7kg of grower feed. If the speed is about 60 RPM, the time it takes is approximately 20 seconds, and for the speed of 120 RPM, it takes about 20 seconds to dispense.

Three trials were done to measure the efficiency and precision of the system when dispensing the feed from the system. Table 2 shows the number of trials, how much of the target feed is to be dispensed, the actual number of dispensed feeds, and the success of the system in fulfilling its purpose. With minimal error, the feed system dispenses less than the actual target feed. With an average deviation of 1.96%, the system works as expected with a margin error at hand. The trial shows that the three trials on the system equate to the efficiency of the system in the dispensing of the correct amount of feed required for the pigs' growth.

Table 3 shows the comparison of manual feeding and the automated system of Project SwineTech. The average time per feeding, with only five minutes allotted time for feeding, shows its efficiency and how it lessens the time for it. Feed wastage is also lessened with the automated system, ensuring feed consistency for the pigs. It can also be seen in the cost cut on labor costs with the presence of an automated system. Without the needed labor, the daily expenses on its cost are also lifted.

The overall cost of the materials for the prototype and the system modules is 3,829 pesos. As shown in Table 4, the project's expense is a one-time payment, ensuring that this sustainable solution to the feeding and watering of pigs is a long-term plan for the raisers. The cost-efficiency of Project SwineTech reflects on the following months and years of usage of the project, wherein the raiser can utilize it to feed and water without hiring staff, causing additional labor costs.

Table 1
Range of Swine Feeds for Each Stage

Stage	Day of Feeding	Feed	Amount per day
Booster	5 - 35	Early Wean <u>Immunobuster</u>	50g
Pre-starter	35 - 56	Early Ween Super Start	500g
Starter	57 - 85	Starter	1.0kg
Grower	86-120	Grower	1.7- 2kg
Finisher	121	Finisher	2.3kg

Table 2

Dispensing Trials (Automated System)

Trial No.	Target Feed (kg)	Dispensed (kg)	Success?
1	1.7	1.65	Yes
2	1.7	1.67	Yes

Table 3

Comparison of Manual and Automated Feeding Systems

Criteria	Manual Feeding	Automated System
Average time per feeding	~30 minutes	~5 minutes
Feed wasted per day.	~0.2–0.3 kg (per pig)	~0.05–0.08 kg (per pig)
Labor required	1 worker	None (monitoring only)
Daily labor cost	₱250	₱0
Feed consistency	Variable	Consistent

Table 4

Cost-Benefit Analysis of Manual Labor vs. Automated System

Item	Manual System (Monthly)	Automated System (One-time + Monthly)
Labor cost	₱7,500	₱0
Feed wastage	₱150 (6 kg @ ₱25/kg)	₱37.50 (1.5 kg @ ₱25/kg)
Maintenance cost	₱0	₱300/month

Table 5

System Performance and Financial Viability

Parameter	Result
System Uptime	98.7%
Feed Dispensing Accuracy	95%

Table 6

System Pricing Summary

Category	Details	Cost (₱)
Main Components	Electronic modules and microcontroller	1,473
Feeding & Watering Structure	Drum, pipes, frame, and fittings	2,356
Total Production Cost		3,829
Add: Setup, testing, labor	Installation, packaging, minor services	800
Add: Developer's Margin (~22%)	Profit margin	1,371
Proposed Selling Price	The final cost to the farmer	6,000

Table 4 shows the analysis of having SwineTech rather than doing manual labor. It dictates the differences in labor cost, feed wastage, and maintenance cost in a month. The labor cost alone, having manual labor costs 7,500 with an average daily wage of 250 pesos, and having your farm automated by SwineTech will save you that much in a month. Feed wastage will also go down a lot from 6 kg to 1.5 kg per month. It shows that SwineTech is cost-efficient.

This shows the estimated maintenance cost of the SwineTech system. The GSM module will need a regular load that costs at least 50 pesos, monthly inspection for continuous effectivity and efficiency, and room for minor repairs just in case of emergency. SwineTech is developed as cost-efficient but is still strong and dependable for growing pigs.

Table 5 illustrates the performance and financial viability of SwineTech. It shows that the uptime of the system garnered a result of 98.7% effectivity and 95% accuracy in dispensing feed, which means that the system is dependable for taking care of pigs. It is also shown that the

return on investment for SwineTech is achieved in only 4-5 months, with the user being able to use it for up to 5-7 years with the right care and maintenance.

Table 6 shows the proposed selling price for users, which includes the labor for the setup and testing of the system and the developer's profit margin. It proves that the system is financially viable for farmers as the return on investment is guaranteed in 4 to 5 months, as shown in Table 8. The system will be a great help for farmers.

CONCLUSIONS AND RECOMMENDATIONS

Conclusion

Project SwineTech successfully developed and tested an automated pig feeding and watering system that integrates both software and hardware to improve efficiency in small-scale piggery operations. The system dispenses feed at consistent times (6:00 A.M. and 6:00 P.M.), ensures accurate feeding amounts, and allows remote monitoring of feed and water levels through SMS alerts using GSM technology. It is cost-effective, adaptable to different pig growth stages, and eliminates human inconsistencies in manual feeding. Overall, the project demonstrates a practical and affordable technological solution that enhances productivity, sustainability, and management in local pig farming.

Recommendations

Future improvements for Project SwineTech include adding a centralized power supply for all components, upgrading the system for medium to large-scale farms with customizable settings based on pig growth and environment, and enabling two-way communication so farmers can remotely control operations like feeding and refilling via text messages. These enhancements aim to make the system more reliable, scalable, and user-friendly.

REFERENCES

- Agaselimova, S.S.. (2024). Automation of feeding and watering cattle. 229-231. 10.23947/interagro.2024.229-231. https://www.researchgate.net/publication/381627359_AUTOMATION_OF_FEEDING_AND_WATERING_CATTLE
- Bong. (2022, March 16). Essential guide on proper feeding and nutrition for pigs. UNAHCO. https://unahco.com/news-events/an-essential-guide-on-proper-feed-and-nutrition-for-pigs/?fbclid=IwY2xjawKZBHleHRuA2FlbQIxMABicmlkETFueWpWWk5NaWpwN1MzSDUzAR7pZyr1AGn6idPpIN5NjwvRBHgwICzkvKTUqdvJZCEnkHqCYQZYVVjLix2sw_aem_Nzyrh8plf6dstOXoy4HJBA#:~:text=A%20pig%20eats%20approximately%204%25%20of%20its%20body,inclusing%20water%2C%20carbohydrates%2C%20proteins%2C%20fats%2C%20vitamins%2C%20and%20minerals
- Buenafior, G. M., Carlos, R. M. & Plata, K. T. (2023). Automatic feeds dispenser for sow and milk feeding of piglets with sms notification. *Ani: Letran Calamba Research Report*, 19(1), 99. <https://ejournals.ph/article.php?id=19736>
- H. J. Lee, Y. K. Park, and J. S. Kim (2021). Design and implementation of an automatic pig-feeding system. <https://www.scribd.com/document/622560783/A-PROPOSED-AUTOMATIC-HOG-FEEDING-MACHINE-USING-TIMER-SWITCH-TECHNOLOGY-AT-BA>

- IOP (Internet of Pigs): Design and implementation of an automatic swine feeder, waterer, and shower system for a livestock multi-purpose cooperative. (2024). *International Research and Innovation Journal*, 1(1). <https://doi.org/10.62293/irij-019ct>
- J. A. Rodriguez and M. A. Gomez (2020). *Automatic Pig Feeding: A Review of Current Systems*. <https://www.scribd.com/document/622560783/A-PROPOSED-AUTOMATIC-HOG-FEEDING-MACHINE-USING-TIMER-SWITCH-TECHNOLOGY-AT-BA>
- Nueva Vizcaya, Philippines. (2020). Economic development - Nueva Vizcaya, Philippines. Nueva Vizcaya, Philippines - Naturally vibrant and watershed haven of the Cagayan Valley. https://nuevavizcaya.gov.ph/economic-development/?fbclid=IwZXh0bgNhZW0CMTEAAR193lpSHv3DQek03xwGEVoQ63eFfhsMJpQa-vP2wLUeqbrvpEm4yTBQpwM_aem_dSqmsG95NE27cxl8bD_SZQ
- Tibreza, J. T., & Perilla, F. S. (2023). Enhancing swine husbandry: The IoT-integrated hogfeedingassistant. <https://vector.unp.edu.ph/index.php/1/article/download/303/286/1390>
- 黄洪平, & Ltd, S. H. E. C. (2013). *CN203748415U - Automatic water feeding system for piggery - Google Patents*. <https://patents.google.com/patent/CN203748415U/en>